

- Célula de carga de tracción/compresión
- Construcción en acero inoxidable
- Herméticamente soldada, protección IP 68 (EN 60529)
- 3000 divisiones O.I.M.L. R60 clase C *
- Disponible en versión **ATEX** (opcional) Zona 0-1-2 (gas) y 20-21-22 (polvo)
- Aplicaciones:
 - Tanques, Tolvas y Cintas pesadoras suspendidas de estructuras
 - Centrales de asfalto y hormigón
 - Medida de fuerza en maquinaria de ensayo
 - Conversión de básculas mecánicas a electrónicas
 - Pesaje aéreo

- Tension/compression load cell
- Stainless Steel construction
- Hermetically welded, protected IP 68 (EN 60529)
- 3000 divisions O.I.M.L. R60 class C *
- Available in **ATEX** version (optional) Zone 0-1-2 (gas) and 20-21-22 (dust)
- Applications:
 - Suspended weighing in Tanks, Hoppers and Belt Conveyor Scales
 - Asphalt and Concrete Plants
 - Force measurement in Test Equipment
 - Conversion from mechanical to electronic scales
 - Crane scales

Modelo Model	Carga nominal Nominal capacity Ln	Clase de precisión Accuracy class * n. OIML	División mínima Minimum division vmin	Carga de servicio Service load 150 % Ln	Carga límite Safe load 200 % Ln
650 250 kg	250 kg	2000	34 g	375 kg	500 kg
650 500 kg	500 kg	3000	50 g	750 kg	1000 kg
650 1000 kg	1000 kg	3000	100 g	1500 kg	2000 kg
650 2000 kg	2000 kg	3000	200 g	3000 kg	4000 kg
650 5000 kg	5000 kg	3000	500 g	7500 kg	10000 kg
650 7500 kg	7500 kg	3000	750 g	11250 kg	15000 kg

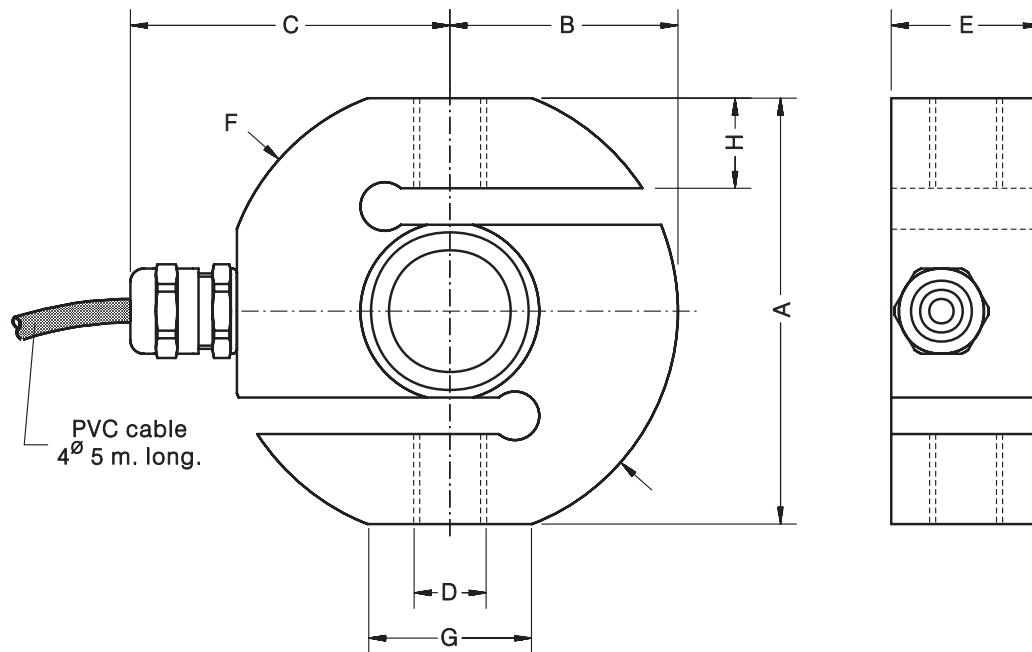

Carga nominal Nominal load	A	B	C	D	E	FØ	G	H	Peso Transport Weight
250-500 kg	70	37.5	50	M12x1.75	24.5	75	26.9	15	1 kg
1-2 t	95	50	60	M20x1.5	30	100	31.2	26	2 kg
5 t	120	62.5	72.5	M24x2	40	125	35	34	4 kg
7.5 t	120	62.5	72.5	M24x2	56	125	35	34	5.5 kg

Dimensiones en mm. *Dimensions in mm.*

ESPECIFICACIONES			SPECIFICATIONS
Cargas nominales (Ln)	250-500-1000- 2000-5000- 7500	kg	Nominal capacities (Ln)
Clase de precisión	3000	n. OIML (2)	Accuracy class
Carga mínima	0	%Ln	Minimum dead load
Carga de servicio	150	%Ln	Service load
Cargas límite	200	%Ln	Safe load limit
Error combinado	< ±0.017	%Sn (1) (2)	Total error
Error repetibilidad	< ±0.015	%Sn	Repeatability error
Efecto de la temperatura: en el cero	< ±0.01	%Sn/5 °C	Temperature effect: on zero
en la sensibilidad	< ±0.006	%Sn/5 °C	on sensitivity
Error de fluencia (30 minutos)	< ±0.016	%Sn (2)	Creep error (30 minutes)
Compensación de temperatura	-10...+55	°C	Temperature compensation
Límites de temperatura	-40...+95	°C	Temperature limits
Sensibilidad nominal (Sn)	2 ±0.1%	mV/V	Nominal sensitivity (Sn)
Tensión de alimentación nominal	10	V	Nominal input voltage
Tensión de alimentación máxima	15	V	Maximum input voltage
Resistencia de entrada	400 ±20	Ω	Input impedance
Resistencia de salida	350 ±3	Ω	Output impedance
Desequilibrio inicial	< ±2	%Sn	No load output
Resistencia de aislamiento	> 5000	MΩ	Insulation resistance
Deformación máxima (a Ln)	< 0.5	mm	Maximum deflection (at Ln)

CONEXION ELECTRICA
ELECTRICAL CONNECTION:

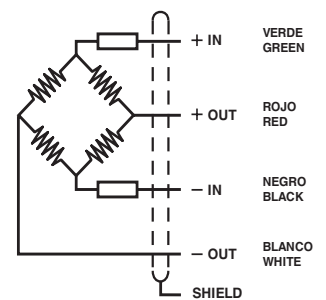

«CONVENIO SIGNOS SALIDA PARA TRACCIÓN»

«OUTPUT SIGNS FOR TENSION APPLICATION»

(1) Error combinado: No Linealidad e Histéresis / Total error: Non Linearity and Hysteresis

(2) Ln = 250 kg: 2000 n. OIML

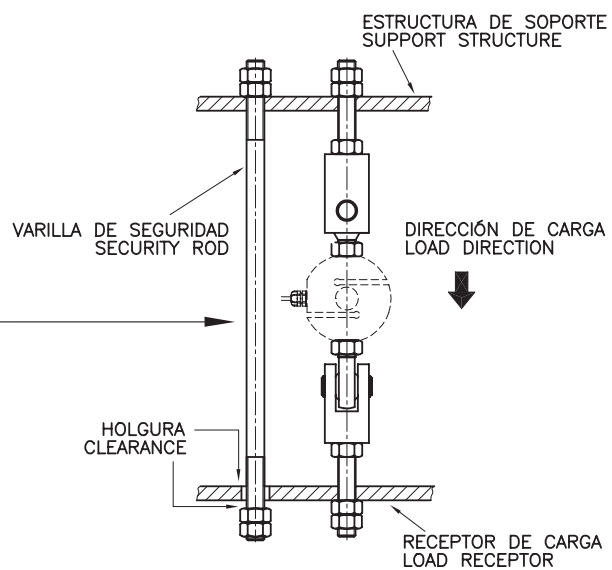
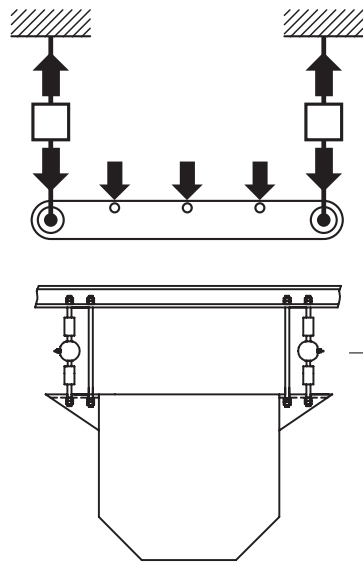
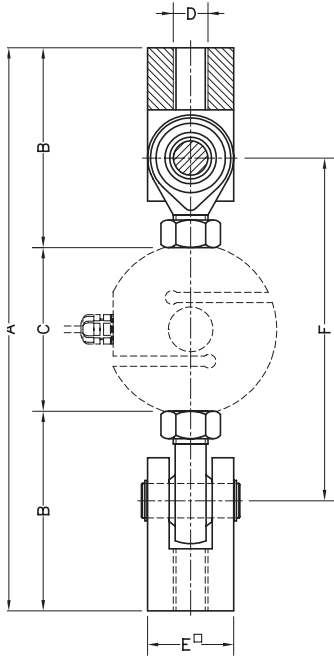
ACCESORIO TRACCION PARA MOD. 650
TENSION ACCESSORY FOR MODEL 650

- Cada accesorio contiene un juego con la parte superior y la parte inferior.
- Each accessory contains a set of the top and bottom.

Accesorio Accessory	Carga nominal Nominal load	A	B	C	D	E	F	Carga límite Ultimate load	Peso transporte Transport weight	Material
TE12x1.75	250-500 kg	236	83	70	M12x1.75	35	148	2000 kg	1.4 kg	Acero cincado Steel zinc-plated
TE20x1.5	1000-2000 kg	327	116	95	M20x2.5	50	199	5050 kg	4.5 kg	
TE24x2	5000-7500 kg	398	139	120	M24x3	60	246	8150 kg	7.8 kg	

Dimensiones en mm. *Dimensions in mm.*

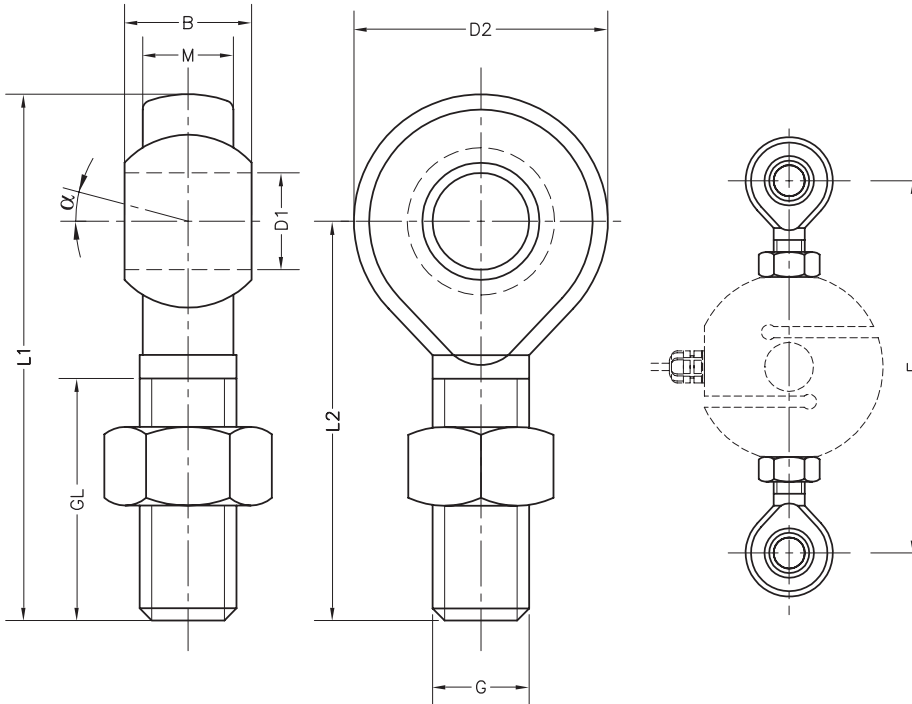
ROTULAS PARA EL MODELO 650
ROD ENDS FOR MODEL 650

- **Material: Acero cincado**
- **Cada accesorio RO contiene un juego de: 2 rótulas y 2 tuercas**

- **Material: Steel zinc-plated**
- **Each accessory RO includes a set of: 2 rod ends and 2 nuts**

Dimensiones Accesorios RO/ RO Accessories Dimensions												
Accesorio Accessory	Capacidad/ Capacity (kg)	D2	B	M	D1	L1	L2	GL	G	α	F	Peso transp. Trans. weight
R012x1.75	250-500	32	16	12	Ø12	70	54	33	M12x1.75	13°	148	0.2 kg
R020x1.5	1000-2000	50	25	18	Ø20	103	78	47	M20x1.5	15°	199	0.8 kg
R024x2	5000-7500	64	20	17	Ø25	126	94	53	M24x2	-	246	1.3 kg

Dimensiones en mm. *Dimensions in mm.*